

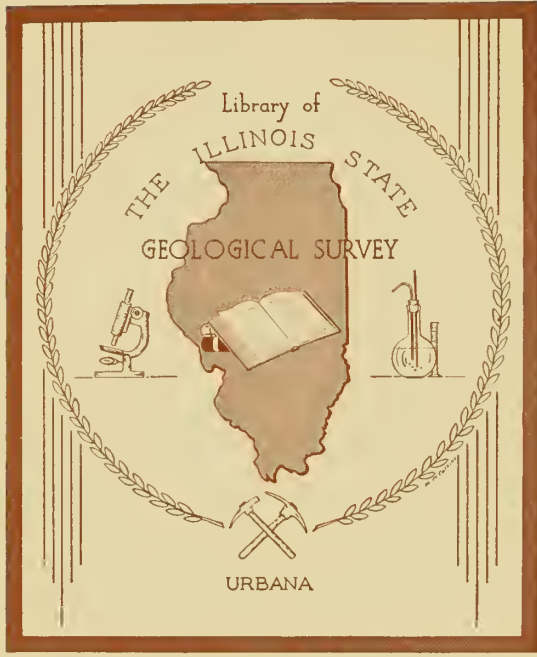

c1



ILLINOIS STATE GEOLOGICAL SURVEY

3 3051 00003 5240



Digitized by the Internet Archive
in 2012 with funding from
University of Illinois Urbana-Champaign

<http://archive.org/details/experimentinconv97squi>

STATE OF ILLINOIS
DWIGHT H. GREEN, *Governor*
DEPARTMENT OF REGISTRATION AND EDUCATION
FRANK G. THOMPSON, *Director*

DIVISION OF THE
STATE GEOLOGICAL SURVEY
M. M. LEIGHTON, *Chief*
URBANA

CIRCULAR—NO. 97

AN EXPERIMENT IN THE CONVERSION OF USED
AUTOMOBILE ENGINES TO OIL-FIELD
POWER AND COMPRESSOR UNITS

BY
FREDERICK SQUIRES

REPRINTED FROM THE OIL AND GAS JOURNAL
VOL. 42, NO. 6, JULY 15, 1943



PRINTED BY AUTHORITY OF THE STATE OF ILLINOIS

URBANA, ILLINOIS
1943

AN EXPERIMENT IN THE CONVERSION OF USED AUTOMOBILE ENGINES TO OIL-FIELD POWER AND COMPRESSOR UNITS

By Frederick Squires

IN the war-time dilemma caused by the demand for more oil in spite of less steel equipment, there appears one fortunate coincidence. Although oil-field engines and compressors may no longer be obtained except with well-nigh prohibitive difficulty, yet because irreplaceable tires are wearing out, automobile engines are becoming increasingly available. It is the purpose of this paper to show how they may be used for power units and compressors with which to increase oil production.

In reply to the requests of conservation authorities that gas be returned to the oil-producing strata in order to increase oil production and to prevent waste of fuel and reservoir energy, the answer in many cases has been that machinery to do this is not available. The use of the automobile engine may in part refute this contention.

Many years ago in the Buck Run field in southeastern Ohio, when the art of secondary recovery of oil was in its infancy, Arthur Smith of Malta, Ohio, repressured his Cow Run sand leases by means of a Ford engine for power and a converted Ford engine for a compressor.

Gordon Smith & Co. of Bowling Green, Ky., make a combined engine and compressor out of a Model A or B Ford engine, of which the end cylinders are used for power in the usual way and the other two cylinders are converted into compressors by sealing down the Ford valves and providing a new head with valves in the head. The unit is portable and is used for air hammers, sprays, and the like.

In a few instances it has been used in the oil fields as a vacuum pump.

In Illinois there is a gas shortage on many of the old leases. At first, single-cylinder oil-field engines were used for power until there was no longer gas enough for fuel to run them, at which time oil engines were substituted. The Dinsmoor Oil Co. has replaced many of these oil engines with Buick automobile engines and has found that these engines are so economical in gas consumption that there is no fuel difficulty even with less gas than would run the original gas engine. It is of course obvious that automobile engines can be used for power in any oil field, which is especially important now that standard oil-field engines can no longer be obtained.

The Compressor

The engines most easily converted to compressors are those made for quantity-production low-priced cars, because they are easiest to obtain and their operation is most generally understood. The engines with cylinders in line are the simplest but the Ford V-8 has many advantages which recommend it.

Time did not permit making tests on each of the many available makes of engines, so this article is written in the hope that the general scheme of conversion will appeal to operators needing compressors to the extent that they will work out the scheme on other makes of engines and that progress will be more rapid and general from this multiplication of effort.

The Geological Survey undertook to

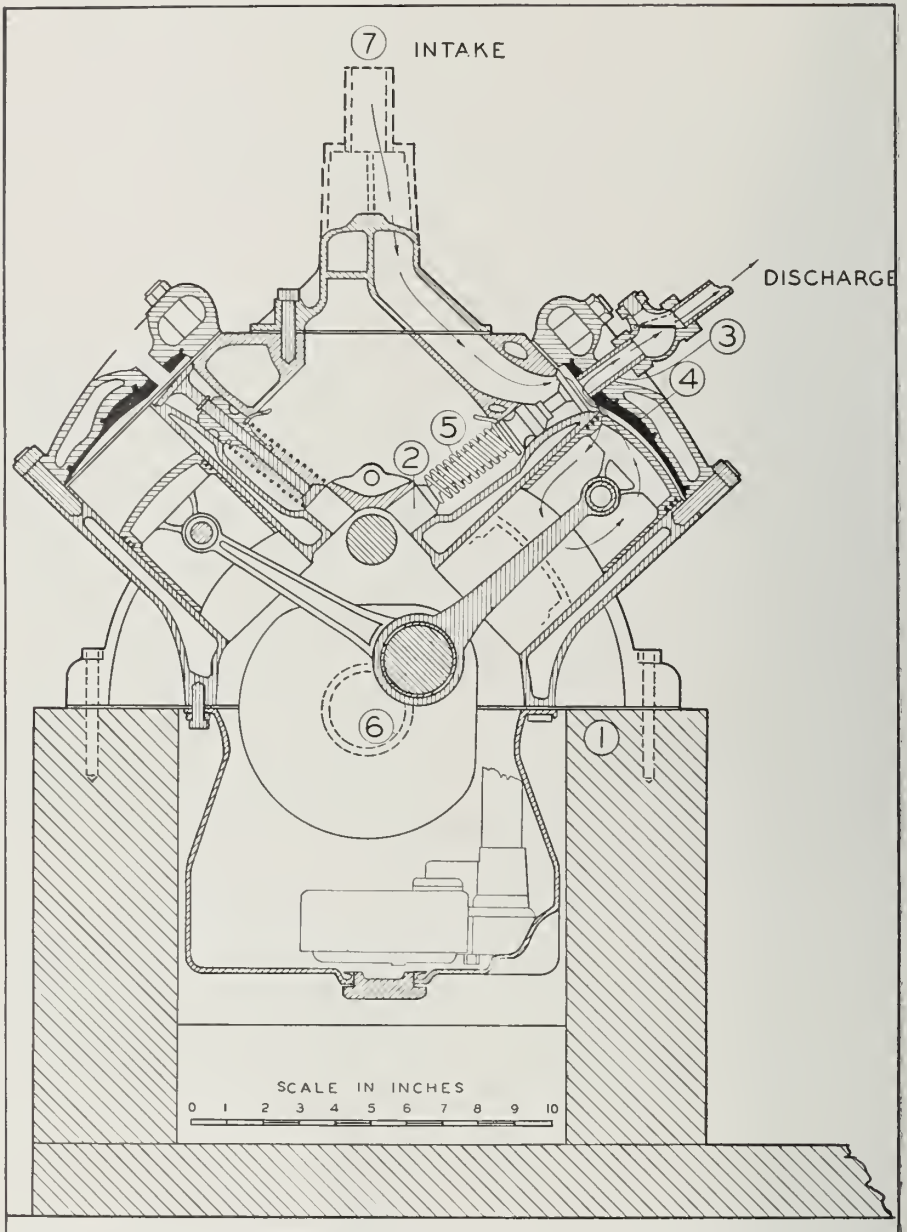

Fig. 1—Section through compressor. Section taken through cylinders farthest from radiator. This shows: (1) Part of engine pan removed. (2) Place from which push rods have been removed. (3) Spark-plug opening reamed out and threaded for $\frac{3}{4}$ -in. pipe. (4) Head drilled for keys and babbitted to reduce dunnage between top of piston and head. (5) A light spring is substituted here for the original heavy spring on the intake valve. (6) Stub shaft is bolted to end of engine shaft on this center. (7) A $\frac{3}{4}$ -in. pipe with valve connects with both openings in the intake manifold. The course of the air or gas is shown by the arrows, entering at 7 and discharging at 3

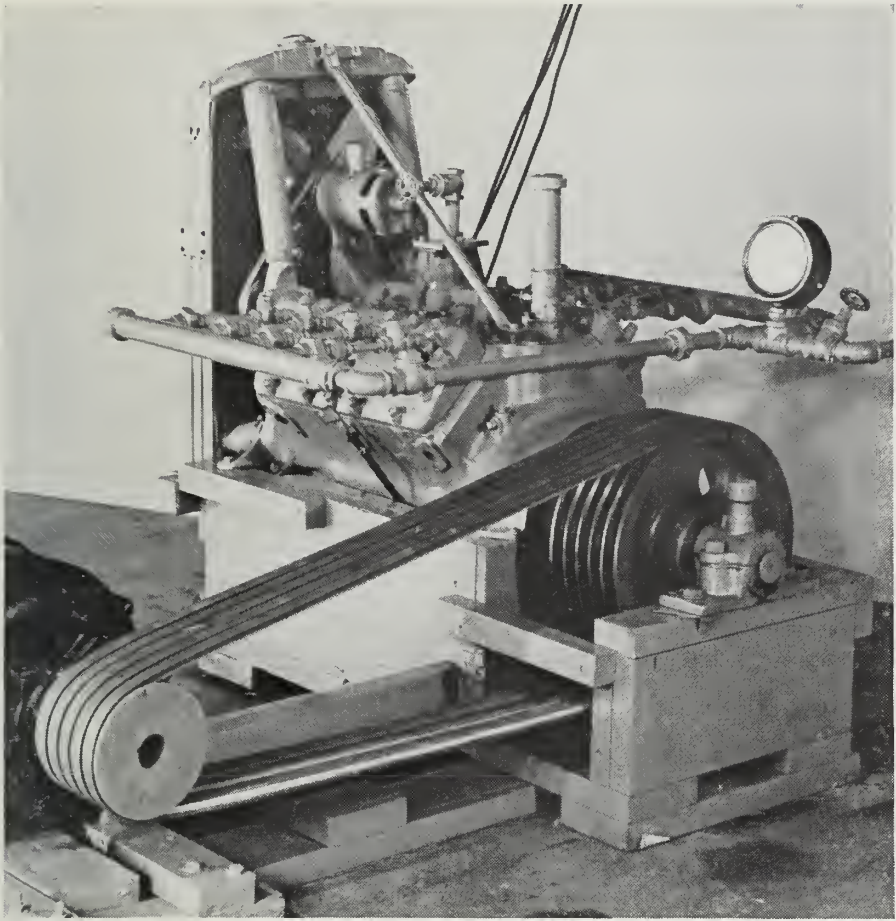

Fig. 2—Photograph of converted compressor. The intake may be seen over the regular engine intake manifold and the discharge to the right of the pressure gage. Any power available in the oil field may replace the motor here used. It will be noted that the oiling and cooling systems are unchanged from the original engine systems. The principal change shown is the system of discharge check valves which replace the engine cam-operated discharge valves

convert a Ford V-8 engine into a compressor, and the following is a description of the method and result.

A rebuilt, second-hand engine was purchased from a local dealer. This was complete as shown in the photograph, Fig. 2, except for the electric motor, pulleys, shaft, bearings, and belts. Since the operation of the compressor does not depend upon the kind of power by which it is driven, there is no discussion of the electric-power unit shown. Any power available in the oil field can be used. In the case in point, a stub shaft was

bolted on to the end of the engine shaft (Fig. 1, No. 6). On it was placed a 15-in. V-belted pulley, and the outer end of the shaft was carried by an ordinary babbitt bearing. The front end of the engine pan was cut away (Fig. 1, No. 1) in order to allow the engine block to rest directly on the frame. A frame of plank was made and the engine set on it and held down by lag screws at each end as shown in Fig. 1. The following changes were made in the engine so that it would operate as a two-cycle

compressor with the valves actuated not by cam-shaft eccentrics but by differential pressure:

All the push rods were removed as shown in Fig. 1, No. 2. The spark-plug openings in the head were reamed out and tapped for $\frac{3}{4}$ -in. pipe, as shown in Fig. 1, No. 3. Into these openings were screwed all-thread nipples connected to 45° angle check valves. The heads were drilled for keys and then babbitted in order to reduce the dunnage between the pistons and the heads. (Spaces above the intake valves were left for free operation. See Fig. 1, No. 4.)

The original strong discharge valve springs were left so as to keep the valves shut at all times, eliminating them from any part in the operation. Very light springs were substituted for the original strong intake springs so that the intake valves would be actuated by the vacuum formed by the downstroke of the piston. This is shown on Fig. 1, No. 5.

Intake Manifold

The intake manifold serves the right and left bank of cylinders separately. These two are brought together (Fig. 1, No. 7) into a single pipe on which is a valve to regulate the amount of air or gas to be drawn in and compressed.

The oiling and cooling systems were unchanged from those on the original engine.

The operation of the compressor is illustrated by the arrowed line running from 7 to 3 (Fig. 1) in the following cycle. As the piston goes down, the vacuum that is created closes the discharge valve, opens the intake valve, and air thus fills the cylinder. The upstroke of the piston closes the intake valve, opens the exhaust valve, and discharges the contents of the cylinder through the discharge valve. This is the whole story. The completed compressor is shown in the photograph (Fig. 2).

This compressor was run at 900 r.p.m. and delivered at the rate of 105,000 cu. ft. per day, as measured by Pitot tube, against atmosphere. It would require a 15-hp. engine as the motor showed a load of about

12 hp. at 120 lb. per sq. in. pressure.

The cost of the compressor, exclusive of motor, pulleys, shaft and belts, amounted to less than \$250. Its fabrication is subject to no priorities except that a used block must be delivered to the Ford agency, which exchanges for it a completely rebuilt motor. The double feature of the intake manifold allows one bank of cylinders to be confined to pure air and the other to pure gas, the mixture taking place in the field line at a distance from the plant, reducing explosion hazard. If air-gas mixtures are compressed, some form of safety device should be employed to avoid the danger of explosion.

One of the best features of the use of eight cylinders is that it permits of two and three staging. The discharge from six cylinders may be re-compressed in the two remaining cylinders for two-staging, and five may discharge into the intake of two, which in turn may discharge into one for a three-stage hookup.

The outfit shown in the photograph has been run for some time in our laboratory and will be given a thorough field test on a repressuring project.

Capacity

Any good pumper could make a similar outfit after looking at this one, and adapt it to the kind of power he has on this lease. An outfit of this size is sufficient for a lease of about two or three intake wells servicing perhaps 12 pumping wells. Where volume requirements are greater, additional units may be added. Varying pressure requirements may be met by single, two or three staging.

The compressors made from used automobile engines may be powered by other automobile engines, and if Ford V-8's are used they may be exchanged for rebuilt units when they begin to show wear.

In this war, materials are as important as men and in providing these materials, we have overcome all obstacles. With such accomplishments in mind, it is reasonable to demand more oil with less steel. But to do it requires new methods; so every new

idea must be received with an open mind. This article suggests one way to get more oil with less steel. It is the author's hope that it will encourage more investigations along the lines suggested or even suggest new methods. Oil is ammunition, and to produce it, our oil sands become vast underground munition plants.

Acknowledgment

Acknowledgment is gratefully made of help from Henry Lane of the Dinsmoor Oil Co., Carl Lowrance of the Bradford Supply Co., and Dr. R. J. Piersol, Dr. A. H. Bell, Dr. J. S. Machin, W. F. Meents, A. W. Gotstein and G.G.Poor, all of the Illinois State Geological Survey.

